

EXPLODED VIEW & PARTS LISTING

Air Operated Double Diaphragm Pump

Model: DP-80BP[x]-HD (XDP)
Polypropylene Series



To Purchase:

- 800-990-7867
- sales@yamadapump.com
- Find My Rep

More Information:

- YouTube: @yamadapump
- yamadapump.com
- Data Sheets | CAD Drawings | Manuals Literature | BOM | Performance Curves

Trial Program

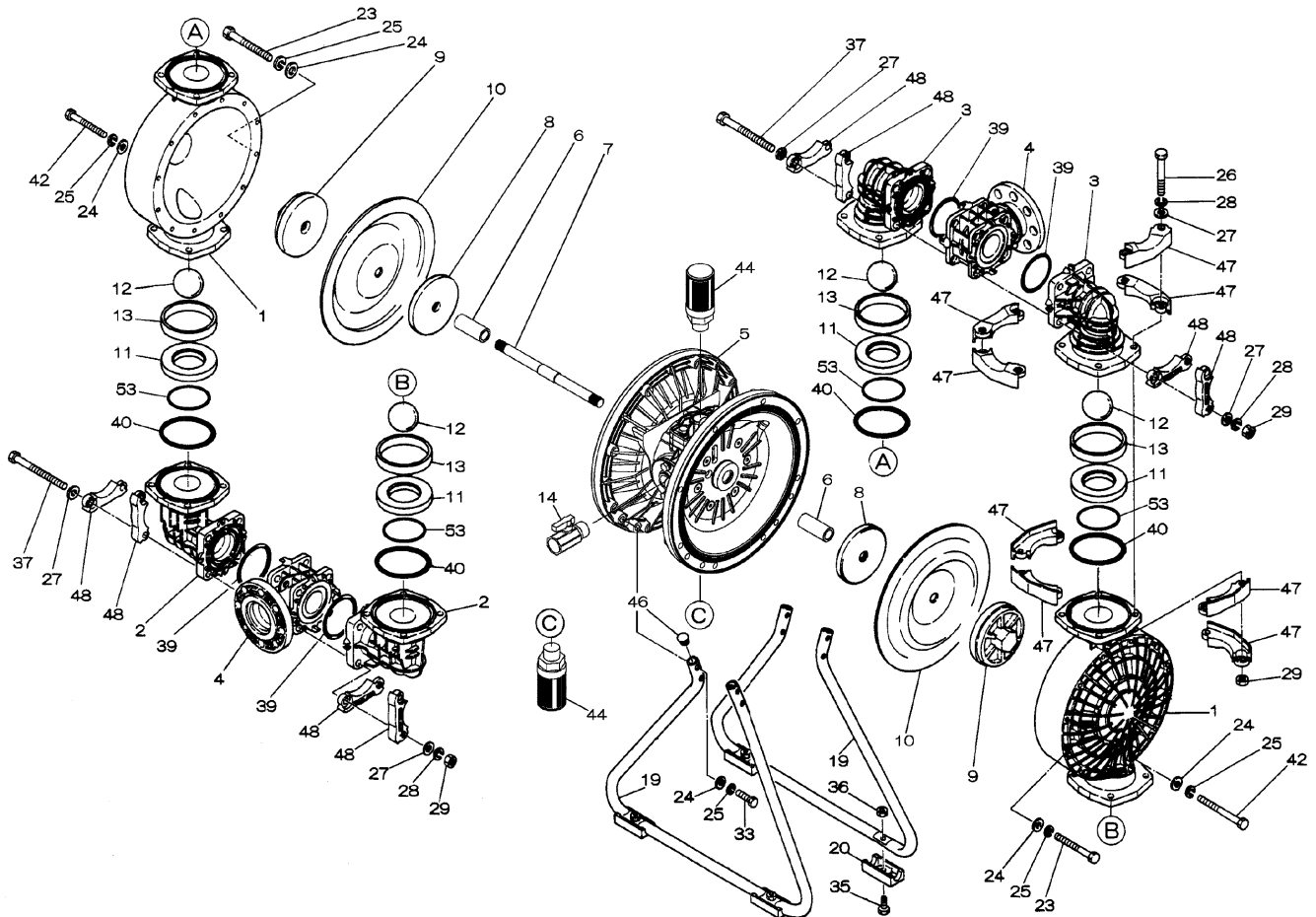

Air Operated Double Diaphragm Pump

804780 Center Body Assembly

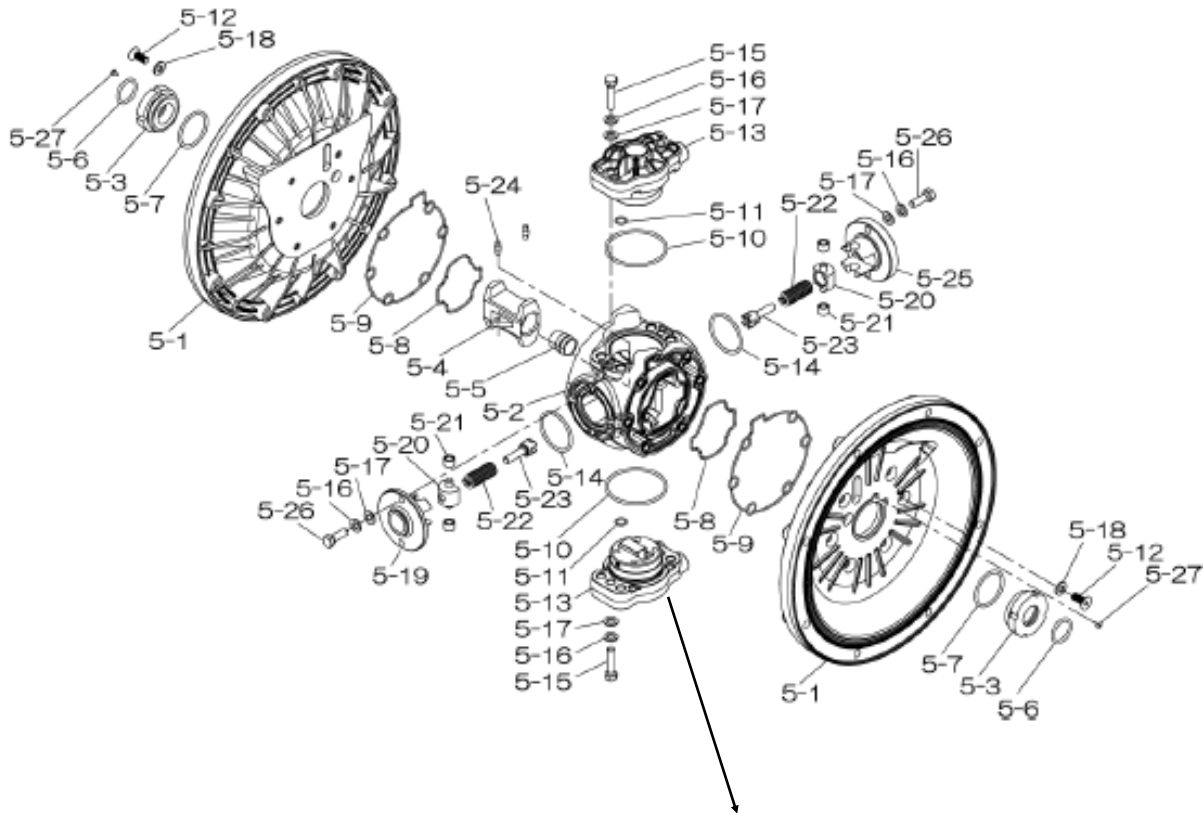

804784 Valve Body Assembly

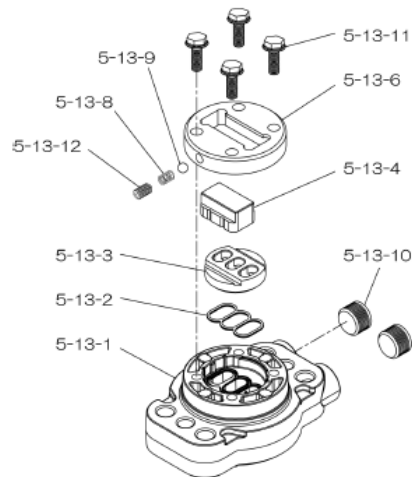

Air Operated Double Diaphragm Pump

	DP-80BPC-HD	DP-80BPN-HD	DP-80BPE-HD	DP-80BPV-HD	DP-80BPH-HD	DP-80BPS-HD			
	854547	854548	854549	854550	854552	854553			
REF. No.	PART No.	PART No.	PART No.	PART No.	PART No.	PART No.	DESCRIPTION	QTY.	REORDER
1	780149	780149	780149	780149	780149	780149	OUT CHAMBER	2	
2	780246	780246	780246	780246	780246	780246	IN MANIFOLD	2	
3	780152	780152	780152	780152	780152	780152	OUT MANIFOLD	2	
4	780250	780250	780250	780250	780250	780250	CENTER MANIFOLD	2	
5	804780	804780	804780	804780	804780	804780	BODY ASSY	1	
5-1	716248	716248	716248	716248	716248	716248	AIR CHAMBER	2	
5-2	716256	716256	716256	716256	716256	716256	BODY	1	
5-3	773066	773066	773066	773066	773066	773066	THROAT BEARING	2	
5-4	716214	716214	716214	716214	716214	716214	SHUTTLE	1	
5-5	773047	773047	773047	773047	773047	773047	CENTER ROD GUIDE	1	
5-6	640023	640023	640023	640023	640023	640023	O-RING	2	
5-7	640133	640133	640133	640133	640133	640133	O-RING	2	
5-8	773040	773040	773040	773040	773040	773040	GASKET	2	
5-9	773041	773041	773041	773041	773041	773041	GASKET	2	
5-10	640138	640138	640138	640138	640138	640138	O-RING	2	
5-11	640007	640007	640007	640007	640007	640007	O-RING	8	
5-12	683812	683812	683812	683812	683812	683812	FLAT SOCKET	12	
5-13	804784	804784	804784	804784	804784	804784	VALVE BODY ASSY	2	
5-13-1	716244	716244	716244	716244	716244	716244	VALVE BODY	1	
5-13-2	773042	773042	773042	773042	773042	773042	GASKET	2	
5-13-3	716246	716246	716246	716246	716246	716246	SEAT	1	
5-13-4	773425	773425	773425	773425	773425	773425	BLOCK	1	
5-13-6	773426	773426	773426	773426	773426	773426	GUIDE PLATE	1	
5-13-8	706612	706612	706612	706612	706612	706612	SPRING WASHER	1	
5-13-9	686271	686271	686271	686271	686271	686271	BALL	1	
5-13-10	772934	772934	772934	772934	772934	772934	PLUG	2	
5-13-11	602300	602300	602300	602300	602300	602300	TAPPING BOLT	4	
5-13-12	610025	610025	610025	610025	610025	610025	HEX SOCKET HEAD SCREW	1	
5-14	640134	640134	640134	640134	640134	640134	O-RING	2	
5-15	611153	611153	611153	611153	611153	611153	BOLT	4	
5-16	631420	631420	631420	631420	631420	631420	SPRING WASHER	8	
5-17	631013	631013	631013	631013	631013	631013	FLAT WASHER	8	
5-18	684987	684987	684987	684987	684987	684987	WASHER	12	
5-19	716249	716249	716249	716249	716249	716249	RETAINER	1	
5-20	713620	713620	713620	713620	713620	713620	SPRING GUIDE	2	
5-21	773067	773067	773067	773067	773067	773067	BUSH	4	
5-22	684537	684537	684537	684537	684537	684537	SPRING	2	
5-23	714446	714446	714446	714446	714446	714446	TRIP ARM	2	
5-24	700231	700231	700231	700231	700231	700231	PIN	2	
5-25	716216	716216	716216	716216	716216	716216	RETAINER	1	
5-26	611149	611149	611149	611149	611149	611149	BOLT	4	
5-27	686337	686337	686337	686337	686337	686337	TAPPING SCREW	2	
6	716253	716253	716253	716253	716253	716253	CENTER BUSHING	2	
7	716252	716252	716252	716252	716252	716252	CENTER ROD	1	
8	711906	711906	711906	711906	711906	711906	CENTER DISK	2	
9	780064	780064	780064	780064	780064	780064	CENTER DISK	2	
10	771857	771704	771858	771801	771705	771977	DIAPHRAGM	2	
11	772098	772098	772098	772098	772098	772098	VALVE SEAT	4	
12	770559	770587	770596	770605	773144	773174	BALL	4	
13	772099	772099	772099	772099	772099	772099	VALVE GUIDE	4	
14	686974	686974	686974	686974	686974	686974	VALVE	1	
19	711927	711927	711927	711927	711927	711927	STAND	2	
20	771865	771865	771865	771865	771865	771865	RUBBER FOOT	4	

Air Operated Double Diaphragm Pump

	DP-80BPC-HD	DP-80BPN-HD	DP-80BPE-HD	DP-80BPV-HD	DP-80BPH-HD	DP-80BPS-HD			
	854547	854548	854549	854550	854552	854553			
REF. No.	PART No.	PART No.	PART No.	PART No.	PART No.	PART No.	DESCRIPTION	QTY.	REORDER
23	683543	683543	683543	683543	683543	683543	BOLT	20	
24	631330	631330	631330	631330	631330	631330	PLAIN WASHER	32	
25	680257	680257	680257	680257	680257	680257	SPRING WASHER	32	
26	621214	621214	621214	621214	621214	621214	BOLT	16	
27	631331	631331	631331	631331	631331	631331	PLAIN WASHER	32	
28	680607	680607	680607	680607	680607	680607	SPRING WASHER	24	
29	628014	628014	628014	628014	628014	628014	NUT	24	
33	621179	621179	621179	621179	621179	621179	BOLT	8	
35	621149	621149	621149	621149	621149	621149	BOLT	4	
36	683837	683837	683837	683837	683837	683837	FLANGED NUT	4	
37	683544	683544	683544	683544	683544	683544	BOLT	8	
39	640070	640070	684123	642070	640070	684123	O RING	4	
40	640080	640080	684125	642080	640080	684125	O RING	4	
42	683552	683552	683552	683552	683552	683552	BOLT	4	
44	804697	804697	804697	804697	804697	804697	MUFFLER	2	
46	683641	683641	683641	683641	683641	683641	CAP	4	
47	771789	771789	771789	771789	771789	771789	PROTECTOR A	32	
48	771790	771790	771790	771790	771790	771790	PROTECTOR B	16	
53	640143	640143	685443	642143	640143	685443	O RING	4	
KIT	K80-PC	K80-PN	K80-PE	K80-PV	K80-PH	K80-PS	LIQUID END		
KIT	K80-AM-DP-HD						AIR MOTOR		

Torque Requirements:

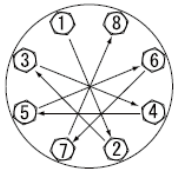

Tightening torque for center rod and out chambers.

- Center Rod 36 ft-lbf {80 N-m}
- Out Chambers 26 ft-lbf {35 N-m}

Tightening torque for manifold retainer bolts.

- BPC/N/EV/H/S-HD 18 ft-lbf {25 N-m}

General Tools:

- Socket wrench - 24mm
- Hexagonal box wrench - 5mm, 6mm
- Small crowbars - 2 (B_C, B_N, B_E, B_V)
- Open-end wrenches - 19mm, 24mm
- Phillips head screw driver

Special Tools:

- Socket (804129) for a guide to remove the throat bearing (sold separately)
- PP Wrench (771868) for removing center disk (sold separately)

Miscellaneous:

- Assembly Oil - Turbine oil none additional class 1 (equivalent to ISO VG32 grade)
- Nuts - M16 x 1.5
- Thread locker
- Urea grease grade (NLGI) No. 2, Shell Alvania Grease S1

Customer Notes	
Model #:	_____
Description:	_____
Serial #:	_____
Date Installed:	_____
Department Location:	_____
Tag/Project:	_____